

Plastic Fans – Industrial fans for “Aggressive Gases/ Vapours” PRF, PRF EX

Installation and Operating Instructions

GB

Document in original language | · 009

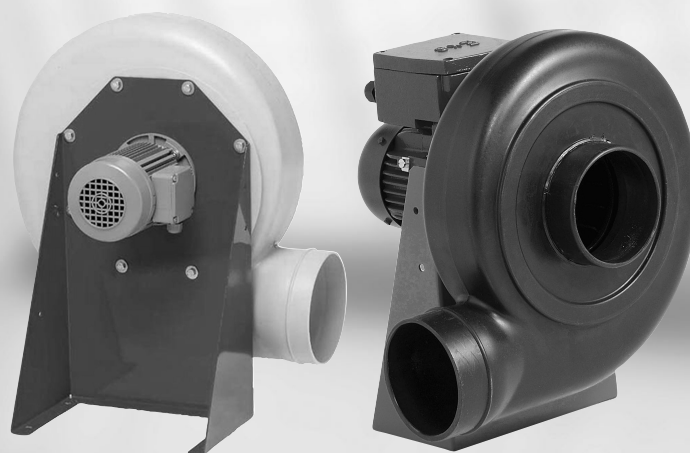

© Copyright Systemair AB
All rights reserved
E&OE

Systemair AB reserves the rights to alter their products without notice.
This also applies to products already ordered, as long as it does not affect the previously agreed specifications.

Contents

| | | | | | |
|-------|------------------------------------------------------|----|------|---------------------------------|----|
| 1 | General information..... | 1 | 15.1 | Safety information..... | 19 |
| 1.1 | Warning symbols..... | 1 | 15.2 | Procedure..... | 19 |
| 1.1.1 | Instruction symbols..... | 1 | 16 | Deinstallation/dismantling..... | 19 |
| 2 | Information on the explosion-protection devices..... | 1 | 17 | Disposal..... | 19 |
| 3 | Important safety information..... | 2 | 18 | Commissioning Report..... | 20 |
| 3.1 | Personnel..... | 3 | | | |
| 3.2 | Personal protective equipment..... | 3 | | | |
| 3.3 | 5 rules of electrical safety..... | 3 | | | |
| 4 | Warranty..... | 3 | | | |
| 5 | Delivery, transport, storage..... | 4 | | | |
| 6 | Description..... | 5 | | | |
| 6.1 | Intended use..... | 5 | | | |
| 6.2 | Incorrect use..... | 5 | | | |
| 6.3 | Technical data..... | 5 | | | |
| 6.4 | Chemical components..... | 6 | | | |
| 6.5 | Dimension..... | 6 | | | |
| 6.6 | Minimum air gap..... | 6 | | | |
| 7 | Name plate and type key..... | 7 | | | |
| 7.1 | Ex key (example)..... | 8 | | | |
| 8 | Marking..... | 9 | | | |
| 9 | Accessories..... | 10 | | | |
| 10 | Installation..... | 11 | | | |
| 10.1 | Installation positions..... | 12 | | | |
| 10.2 | Lightning protection device..... | 12 | | | |
| 11 | Electrical connection..... | 12 | | | |
| 11.1 | Protecting the motor..... | 13 | | | |
| 11.2 | Variable-speed fans..... | 13 | | | |
| 12 | Commissioning..... | 14 | | | |
| 12.1 | Safety information..... | 14 | | | |
| 12.2 | Preconditions..... | 14 | | | |
| 12.3 | Tests..... | 14 | | | |
| 13 | Operation..... | 15 | | | |
| 13.1 | Safety information..... | 15 | | | |
| 14 | Troubleshooting/maintenance/repair..... | 16 | | | |
| 14.1 | Troubleshooting..... | 16 | | | |
| 14.2 | Maintenance..... | 17 | | | |
| 14.3 | Spare parts..... | 18 | | | |
| 15 | Cleaning..... | 19 | | | |

1 General information

1.1 Warning symbols



Danger

Direct hazard

Failure to comply with this warning will lead directly to death or to serious injury.



Caution

Hazard with a low risk

Failure to comply with this warning may lead to moderate injuries.



Warning

Potential hazard

Failure to comply with this warning may lead to death or serious injury.

Important

Hazard with risk of damage to objects

Failure to comply with this warning will lead to damage to objects.



Note:

Useful information and instructions

1.1.1 Instruction symbols

Instruction

- ◆ Carry out this action
- ◆ (if applicable, further actions)

Instruction with fixed sequence

1. Carry out this action
2. Carry out this action
3. (if applicable, further actions)

2 Information on the explosion-protection devices



Danger

Explosion protection!

This warning marks information which applies if the device is used in a potentially explosive atmosphere. Failure to comply with this information will result in loss of explosion protection and may lead to serious injury or death.



Warning

Hazard resulting from improper use of the fans.

These operating instructions and the fan name plate describe how to use the EX fans safely.

- ◆ Read the operating instructions completely and carefully.
- ◆ If used in potentially explosive atmospheres, examine the name plate. Only use type PRF-EX fans.



Warning

Protective clothing must be worn in potentially explosive atmospheres to reduce the risks to employee health.

- ◆ Wear protective equipment during all work in the vicinity of the fan, details see 3.2 *Personal protective equipment*, page 3.
- ◆ Comply with the information on personal protective equipment displayed in the work area.

**Warning**

Regarding the choice of material, the EX fans fulfil the requirements of Standard DIN 14986 (Construction of fans for use in potentially explosive atmospheres) as a result of specific protection measures in areas of potential contact between rotating and stationary components (rotor/intake nozzle).

A safety clearance to the intake nozzle is guaranteed for the rotating part. The plant builder is responsible for selecting the materials for the fixed peripheral parts for fan designs without protective grids. Only pairs of materials according to Standard DIN EN 14986 are to be used.

**Warning**

The temperature class stated on the EX name plate (motor) must match the temperature class of the combustible gas which may occur, or the motor must have a higher temperature class.

**Danger****Explosion protection**

Transport damage or failure to comply with this information can lead to loss of explosion protection.

- ◆ In the event of recognisable transport damage, contact the manufacturer and do not put the device into operation.

**Warning**

The effects of lightning strikes must be limited so that hazards are prevented. In addition to protection against the effects of "direct" lightning strikes, this also includes protection against lightning strikes at a distance from the building. The latter can lead to hazards resulting from excess voltage.

- ◆ Carry out a risk analysis according to DIN VDE 0100, part 443, with a balance between protection and consequences, taking the probability of the occurrence of excess voltage into account.
- ◆ Protect all devices, protective systems and components by using suitable lightning and excess voltage protection measures.

**Warning****Ignition protection class „d“**

If fans are controlled using motors with a "d" ignition protection class with a frequency converter, then thermal protection via a PTC resistor in the motor is required.

3 Important safety information

Planners, plant builders and operators are responsible for the proper assembly and intended use.

- ◆ Read the operating instructions completely and carefully.
- ◆ Keep the operating instructions and other valid documents, such as the circuit diagram or motor instructions, with the fan. They must always be available at the place of use.
- ◆ Observe and respect local conditions, regulations and laws.
- ◆ Abide by the system-related conditions and requirements of the system manufacturer or plant constructor.
- ◆ Safety elements may not be dismantled, circumvented or deactivated.
- ◆ Only use the fan in a flawless condition.
- ◆ Provide generally prescribed electrical and mechanical protective devices.
- ◆ During installation, electrical connection, commissioning, troubleshooting, and maintenance, secure the location and premises against unauthorised access.
- ◆ Do not circumvent any safety components or put them out of action.
- ◆ Before any work on the fan, test absence of voltage.
Even when the motor is stopped, dangerous voltages may be present on terminals.
- ◆ Keep all the warning signs on the fan complete and in a legible condition.
- ◆ The device is not to be used by persons (including children) with reduced physical, sensory or mental capabilities, or lack of experience and knowledge, unless they have been given supervision or instruction.
- ◆ When lifting the device, use suitable lifting gear.
- ◆ Do not allow children to play with the device.

3.1 Personnel

The fan may only be used by qualified, instructed and trained personnel. The persons must know the relevant safety directives in order to recognise and to avoid risks. The individual activities and qualifications can be found in Table 1 *Qualifications*, page 3.

Table 1 Qualifications

| Activities | Qualifications | |
|----------------------------------------------------------------|---------------------------------------------------------------------|----------------------------------|
| Storage, operation, transport, cleaning, disposal | Trained personnel (see following note) | |
| Electrical connection, commissioning, electrical disconnection | Electrical expert or matching qualification | |
| Installation, disassembly | Fitter or matching qualification | |
| Maintenance | Electrical expert or matching qualification | Fitter or matching qualification |
| Repair | Electrical expert or matching qualification | Fitter or matching qualification |
| | Smoke extraction fans and EX fans only by agreement with Systemair. | |



Note:

The operator is responsible for ensuring that personnel are instructed and have understood the contents of the operating instructions. If something is unclear, please contact Systemair or its representative.

3.2 Personal protective equipment

◆ Wear protective equipment during all work in the vicinity of the fan.

- protective working clothes
- protective working gloves
- goggles
- protective working shoes
- helmet
- hearing protection

3.3 5 rules of electrical safety

1. Disconnect (disconnection of the electrical system from live components at all terminals)
2. Prevent reactivation
3. Test absence of voltage
4. Ground and short-circuit
5. Cover or restrict adjacent live parts

4 Warranty

For the assertion of warranty claims, the products must be correctly connected and operated, and used in accordance with the data sheets. Further prerequisites are a completed maintenance plan with no gaps and a commissioning report. Systemair will require these in the case of a warranty claim. The commissioning report is a component of this document. The maintenance plan must be created by the operator, see section Maintenance.

5 Delivery, transport, storage

Safety information

Warning: Risk from rotating fan blades

- ◆ Prevent access by unauthorised persons by safety personnel or access protection.

Warning: Suspended loads

- ◆ Do not walk under suspended loads.
- ◆ Make sure that there is nobody under a suspended load.

Delivery

Each fan leaves our plant in an electrically and mechanically proper condition. We recommend transporting the fan to the installation site in the original packaging.

Checking delivery

- ◆ Check the packaging and the fan for transport damage. Any findings should be noted on the cargo manifest.
- ◆ Check completeness of the delivery.

Unpacking

When opening the transport packaging, there is a risk of damage from sharp edges, nails, staples, splinters etc.

- ◆ Unpack the fan carefully.
- ◆ Check the fan for obvious transport damage.
- ◆ Only remove the packaging shortly before assembly.

Transport

Safety information

Warning: Electrical or mechanical hazards due to fire, moisture, short circuit or malfunction.

- ◆ Never transport the fan by the connecting wire, terminal box, impeller, protection grille, inlet cone or silencer.
- ◆ In open transport, please make sure that no water can penetrate into the motor or other sensitive parts.
- ◆ We recommend transporting the fan to the installation site in the original packaging.

Caution: If transported without care during loading and unloading, the fan may be damaged.

- ◆ Load and unload the fan carefully.
- ◆ Use hoisting equipment that is suitable for the weight to be hoisted.
- ◆ Observe the transportation arrows on the packaging.
- ◆ Use the fan packaging exclusively as transport protection and not as a lifting aid.

Storage

- ◆ Store the fan in the original packaging in a dry, dust-free location protected against weather.
- ◆ Avoid the effects of extreme heat or cold.

Hazard due to loss of function of the motor bearing

- ◆ Avoid storing for too long (recommendation: max. 1 year).
- ◆ Check that the motor bearing functions properly before installation.

6 Description

6.1 Intended use

Intended use PRF and PRF EX

- The fans are intended for installation in ventilation systems.
- The fans are exclusively intended for extract air applications.
- The fans have been developed and built to convey air with the simultaneous presence of corrosive gases/vapours.

Intended use PRF EX

- The EX fans are not ready-for-use products, but have been designed as components for ventilation equipment, machines and systems. They may only be operated when they have been installed in accordance with their use and safety has been ensured by protective devices pursuant to DIN EN 294 (DIN EN ISO 12100-1).
- The fans are only intended for conveying air or explosion-capable atmospheres of Zone 1, Category 2G, and Zone 2, Category 3G.

6.2 Incorrect use

Incorrect use refers mainly to using the fan in another way to that described. The following examples are incorrect and hazardous:

Incorrect use PRF and PRF EX

- Conveying of abrasive, combustible air or air with solid particles.
- Conveying media which attack the materials of the fan (housing, rotor and slip rings of polypropylene).
- Operation without duct system or protection grille
- Operation with the air connections closed

Incorrect use PRF

- Conveying of explosive and combustible media

Incorrect use PRF EX

- The fan is not suitable for intake of aggressive media or media with a dust content so high that dust deposits on the impeller or fan housing can affect the operation of the fan.

6.3 Technical data

| | |
|----------------------------------------------------------------------------------------------------------------------|----------------------------------------------------|
| Max. ambient temperature [°C] | see data sheet, available in our online catalogue. |
| Max. temperature of transported air [°C] | see data sheet, available in our online catalogue. |
| Sound pressure [dB] | see data sheet, available in our online catalogue. |
| Voltage, current, frequency, enclosure class, weight | see name plate of the fan |
| The motor data can be found on the name plate of the motor, or in the technical documents of the motor manufacturer. | |

The data on the name plate of the fan apply to "standard air" according to ISO 5801.

- Housing material: UV resistant PE (PRF-EX from PP)
- Impeller material: PP



Warning

- Inspected according to ATEX Directive 2014/34/EU
- Antistatic housing

The explosion-protected fans can be used for temperature classes T1 to T4 or T6 and have been registered for transporting potentially explosive atmospheres in Zone 1 and 2, category 2G and 3G, with the groups IIA, IIB and H² (only PRF-EX Ex d).

PRF-EX Ex d has an IEC standard motor in an Ex d finish which can be controlled via a frequency inverter and has an added-on terminal box in an Ex e finish. Motor protection is via an integrated PTC resistor with connection to a motor protection switching device e.g. U-EK230E.

6.4 Chemical components

The standard plastic types used are polyethylene (PE) and polypropylene (PP). As a matter of principle, the rotor material is the indicator for the selection.



Note:

The list "COMPATIBILITY WITH CHEMICAL AGENTS" is available in our online catalogue. This list has been produced to the best of our knowledge, but we cannot guarantee the correctness of all statements. Examination of the media to be transported is a matter for the plant operator. Here, it is merely a question of a recommendation.

6.5 Dimension

Table 2 Dimensions

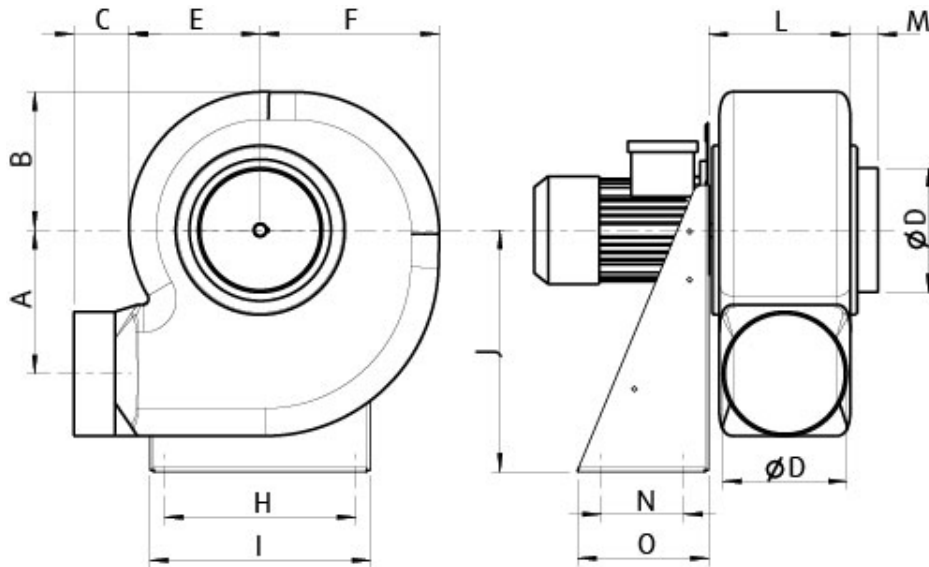

| [mm] | A | B | C | ØD | E | F | H | I | J | L | M | N | O |
|-----------------|-----|-----|----|-----|-----|-----|-----|-----|-----|-----|----|-----|-----|
| PRF, PRF EX 125 | 142 | 165 | 60 | 125 | 150 | 183 | 200 | 235 | 250 | 115 | 40 | 100 | 140 |
| PRF, PRF EX 160 | 182 | 210 | 80 | 160 | 190 | 237 | 255 | 290 | 310 | 150 | 40 | 100 | 140 |
| PRF, PRF EX 180 | 205 | 230 | 80 | 180 | 205 | 275 | 277 | 320 | 350 | 160 | 40 | 120 | 190 |
| PRF, PRF EX 200 | 227 | 245 | 80 | 200 | 220 | 313 | 320 | 355 | 410 | 170 | 40 | 150 | 230 |
| PRF, PRF EX 250 | 284 | 330 | 80 | 250 | 270 | 380 | 330 | 370 | 495 | 195 | 40 | 170 | 250 |

6.6 Minimum air gap

The following table shows the minimum air gap between the rotor and the housing.

| Size | minimum air gap [mm] | Size | minimum air gap [mm] | Size | minimum air gap [mm] |
|------|----------------------|------|----------------------|------|----------------------|
| 125 | 2.00 | 180 | 3.0 | 250 | 4.5 |
| 160 | 2.50 | 200 | 3.5 | | |

7 Name plate and type key

- 1 Type designation
- 2 Voltage/current/frequency
- 3 Power
- 4(a/b/c) Enclosure class/fan impeller speed/weight
- 5 Article number/production number/manufacturing date
- 6 Certifications
- 7 Certification office/ATEX registration number
- 8 Identification
- 9 Manufacturer Address
- 10 Insulation class
- 11 Production number

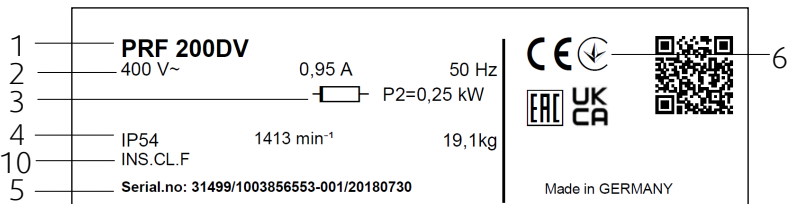
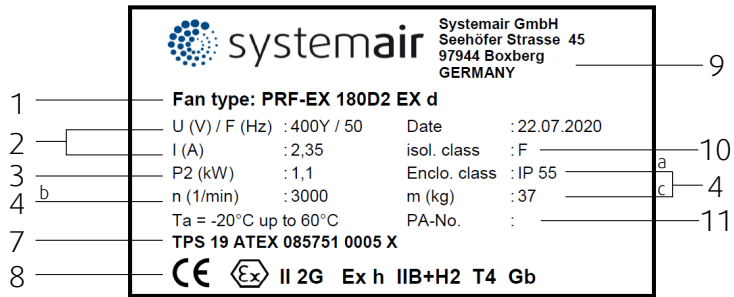



Table 3 Type key PRF

| | | | | | |
|-----|-----|----|---|------|--------------------------------------------------------------------------|
| PRF | 200 | DV | - | EX d | |
| | | | | | Ignition protection class |
| | | | | | Pressure-proof encapsulation |
| | | | | | - Not classified (< 0.75kW or PRF EX) |
| | | | | | IE2 International efficiency class 2 |
| | | | | | IE3 International efficiency class 3 |
| | | | | | Motor type |
| | | | | | D2 2poled/controllable by frequency converter/3 phased |
| | | | | | D4 4 poled/controllable by frequency converter/3 phased |
| | | | | | DV 4 poled/voltage controllable/3 phased |
| | | | | | E4 4 poled/controllable by frequency converter/1 phased |
| | | | | | Flange diameter |
| | | | | | Fan type |
| | | | | | PRF Plastic Fans – Industrial fans for “Aggressive Gases/Vapours” |

7.1 Ex key (example)

| | | | |
|-----------------------------------------------------------------------------------|----------------------------------------------------------|-----------------------------------------------------------------------------------|---------------------------|
| CE | 0123 |  | TPS 19 ATEX 085751 0005 X |
| CE | CE sign | | |
| 0123 | Notified office (quality assurance system) | | |
|  | Device certified for Ex area | | |
| II | Device group (here: use above ground) | | |
| 2G | Device category and classification (G = gas; D = dust) | | |
| Ex h | Ignition protection class (constructive safety) | | |
| Ex d | Ignition protection class (pressure-proof encapsulation) | | |
| Ex e | Ignition protection class (increased safety) | | |
| IIB | Group | | |
| T4 or T6 | Temperature class | | |
| Gb | EPL Equipment Protection Level | | |
| TPS 19 ATEX 085751 0001 X | ATEX registration number | | |

8 Marking

Table 4 Marking

| Designation | | Marking | |
|--------------------------------------|----------------|---------------------------------------------|----------------------------------------------------------------------------------------------------------------------------------------------------------------------------------------------------------------------------------------------------------------------------------------------|
| Device group II | Classification | | All areas with explosion-capable atmosphere apart from mining, underground and above ground in cases of mien damp. |
| Device category/ classification | „2G“ | 2 | Category 2 / Zone 1 / high safety / Devices of this category are intended for use in areas in which occasional occurrence of an explosion-capable atmosphere of gases, vapours, mists is to be expected. Increased safety, Ex e. |
| | „3G“ | 3 | Category 3 / Zone 2 / normal safety / Devices of this category are intended for use in areas in which occurrence of an explosion-capable atmosphere of gases, vapours, mists is not to be expected, but if it does occur then in all probability only rarely and for a short period of time. |
| | | G | Gases / Vapours / Mists |
| Ignition protection class mechanical | “h” | Constructive safety | DIN EN ISO 80079-37:2016 |
| Ignition protection class electrical | „d“ | Pressure-proof encapsulation d | Motor: Pressure-proof encapsulation |
| | „e“ | Increased safety, Ex e | Terminal box: Occurrence of sparks, light arc or inadmissible temperatures which could act as sources of ignition is prevented by additional measures and an increased degree of safety. |
| Group | II | IIA | Propane |
| | | IIB | Ethylene |
| | | IIC | Hydrogen |
| Temperature class | T1 | 450 °C | I: Methane |
| | | | IIA: Acetone, ammoniac, methane, methanol, propane, toluene |
| | | | IIB: Town gas |
| | T2 | 300 °C | IIC: Hydrogen |
| | | | IIA: Ethyl alcohol, n-butane |
| | | | IIB: Ethylene |
| T3 | 200 °C | IIC: Acetylene | |
| | | IIA: Otto fuels, diesel fuels, heating oils | |
| T4 | 135 °C | IIB: Hydrogen sulphide | |
| T5 | 100 °C | IIA: Acetaldehyde, ethyl ether | |
| T6 | 85 °C | There is no gas in this class | |
| EPL Equipment Protection Level | Gb | | Carbon disulphide |
| | | | Devices of this category are intended for use in areas in which occasional occurrence of an explosion-capable atmosphere of gases, vapours, mists is to be expected. |



9 Accessories



Note:

For details of the accessories, please check our online catalog or contact Systemair.

Table 5 Accessories

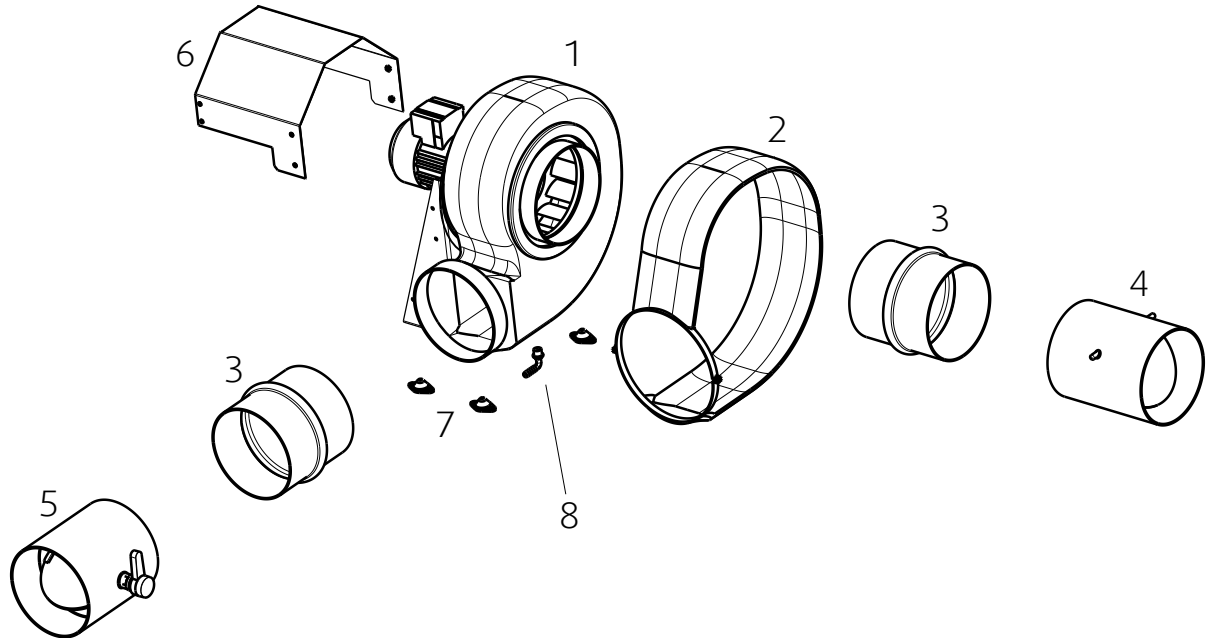

| | | | | | |
|---|-------------|---------------------|---|-------|-----------------------------------|
| 1 | PRF, PRF EX | Fan | 5 | VKA-P | Adjust. damper |
| 2 | VP | Splinter protection | 6 | WSD | Weather roof KIT (not for PRF EX) |
| 3 | ASS-P | Flexible connection | 7 | SD | Vibration damper |
| 4 | VKS-P | Gravity shutter | 8 | | Drain plug 3/8" |

10 Installation

Safety information

Warning: Danger from falling fan or fan parts.

- ◆ Check the surface before installation for load bearing capacity.
- ◆ Consider all static and dynamic loads when selecting hoisting equipment and fastening components.

General safety information

- ◆ Fans installed in areas where personnel access regularly must be equipped with a splinter guard, please contact Systemair.
- ◆ Observe 3 *Important safety information*, page 2
- ◆ Use installation material with fire resistance classes that meet temperature requirements.
- ◆ Provide contact and intake protection and ensure safety distances according to DIN EN ISO 13857 and DIN 24167-1.
- ◆ To reduce transmission of vibration to the duct system, we recommend flexible connections from our accessory range, see chapter Accessories.
- ◆ The materials the fan is made of have to be compatible to the transported media.
- ◆ Pay attention to the safety data sheet of the chemical substances transported with the fan.

Preconditions

- ◆ Ensure that the fan and all its components are undamaged.
- ◆ Fit the fans in such a way that there is sufficient access for installation, troubleshooting, maintenance and repair.
- ◆ Protect against dust and moisture when installing.
- ◆ Ensure that the information on the name plates (fan and motor) matches up with the operating conditions.



Danger

Risk of ignition of a potentially explosive atmosphere!

- ◆ Seal the system carefully.
- ◆ Install accessory parts correctly.
- ◆ The housing must be protected from shock impacts, using splinter protection if necessary (accessory)!

Aluminothermic Reaction

At high air speeds, in combination with aluminium, rust particles may lead to an aluminothermic reaction which, in the worst case, can trigger the ignition of an explosive atmosphere. Upstream or downstream components, or those which lie directly in the air flow, must not have any unprotected aluminium or steel surfaces. To prevent an aluminothermic reaction, surface protection is required which at least fulfils the cross-cut test classification 2 / DIN EN ISO 2409. Steel with an electro-galvanised or hot-dip galvanised surface is not critical. However, care must be taken that appropriate protection is also applied to the cut edges.

Important

Damage to the bearings or other parts of the fan can occur.

- ◆ Do not place a duct bend directly before or after the fan!
- ◆ Ensure a smooth and constant air flow to the device.

- Rectangular duct system: **D** = Hydraulic diameter
- Round duct system: **D** = Nominal diameter

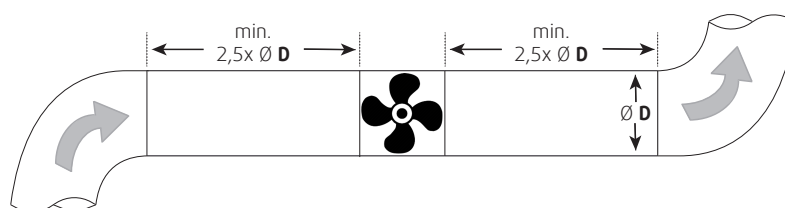

Fig. 1 Straight ducts

10.1 Installation positions

The installation is possible in any mounting position.

10.2 Lightning protection device

- ◆ If the risk assessment shows that there is the risk of an atmospheric discharge, lightning protection measures must be taken. For reasons of operational safety, provide for a suitable lightning protection system according to country specific directives (e.g. DIN VDE 0185).

11 Electrical connection

Safety information



Danger

Risk of ignition of a potentially explosive gas/air atmosphere!

If the wire ends which have not been connected are fitted to the external current circuits within an area with a potentially explosive atmosphere,

- ◆ a connection box (with its own certification and explosion-protection identification) which has been selected as suitable for this area must be used.
- ◆ the electrical data, information on temperature monitoring and on admissible operation with part voltage, if applicable, can be found on the relevant data sheet.
- ◆ Electronic accessories without explosion-protection (e.g. RTRD control device and UEK motor protection) must be installed outside the explosion capable area.
- ◆ Speed control by frequency converter is only admissible for devices with the „Pressure-proof encapsulation Ex d“ ignition protection class.

The types #33985 PRF-EX 180D4 and #34532 PRF-EX 125D2 are not speed controllable by frequency converter.

Protection against explosions in general:

- ◆ Earth at the planned earthing point.
- ◆ In hazardous areas connect conductive components to a potential equalisation system.

Warning: Danger from electrical voltage!

- ◆ Observe the 5 rules of electrical safety, see 3.3 *5 rules of electrical safety*, page 3.
- ◆ Prevent the ingress of water into the connection box.
- ◆ Electrical connection may only be carried out by adequately qualified persons, details see Table 1 *Qualifications*, page 3.

Connection

- ◆ Check if the data on the nameplate matches the connection data.
- ◆ Complete the electrical connection according to the circuit diagram.
- ◆ Use all of the locking screws.
- ◆ Insert the screws by hand to avoid damaging the thread.
- ◆ Tighten all glands well in order to guarantee protection class IP.
- ◆ Screw the lid of the terminal box/inspection switch evenly tight.
- ◆ Connect the cable end in a dry environment.
- ◆ Install a circuit breaker in the permanent electrical installation, with a contact opening of at least 3 mm at each pole.
- ◆ Potentially, the fans may become charged with static electricity. If this represents a risk, please contact Systemair.

Protective grounding wire

The protective grounding must have a cross-section equal to or greater than that of the phase conductor.

Residual current circuit breaker

All-current-sensitive residual current circuit breakers are required for use in alternating-current systems with 50/60 Hz, in combination with electronic devices such as EC motors, frequency converters or uninterruptible power supplies (UPS).

11.1 Protecting the motor

Important

Damage to motor due to overcurrent, overload or short circuit.

- ◆ Lead-out temperature monitors must be integrated in the control circuit in such a way that, if a fault occurs, the motor cannot switch on again automatically after it has cooled down.
- ◆ Motor lines and temperature monitor lines should be laid separately on principle.
- ◆ Without thermal protection: Use a motor protection switch!

11.2 Variable-speed fans



Warning

Resonant frequencies may result in increased vibration in certain speed ranges. These vibrations may destroy components.

- ◆ Only operate the fan outside these speed ranges.
- ◆ Pass through these speed ranges so quickly that any vibration cannot exceed the admissible resonant frequency values.
- ◆ Observe the operating instructions of the frequency converter.



Caution

Damage as a result of incorrect commissioning of the frequency converter.

- ◆ Install the fan and frequency converter as near as possible to one another.
- ◆ Use shielded cables.
- ◆ All components (fan, frequency converter and motor) must be grounded.
- ◆ We recommend using all-pole sinus filters.
- ◆ Avoid running the fan via the frequency converter below 10 Hz.
- ◆ Heating of the motor due to use of a variable frequency drive must be checked in the application by the customer.
- ◆ Never exceed the maximum impeller rotation speed indicated on the name plate of the fan.

12 Commissioning

The system operator is responsible for the correct operation of the fan and/or the system!

Warranty claims can only be made if commissioning work is carried out correctly and written evidence thereof is provided.

It is recommended to fill out the commissioning report 18 *Commissioning Report*, page 20.

12.1 Safety information

- ◆ Commissioning may only be carried out by adequately qualified persons, details see Table 1 *Qualifications*, page 3.
- ◆ Pay attention to the safety data sheet of the chemical substances transported with the fan.



Warning

- ◆ Comply with fundamental information in the commissioning of the EX fan:
 - DGUV 113-001 (explosion protection rules (EX-RL))
 - TRGS 727 (Avoiding ignition hazards due to electrostatic charges).
 - Observe and respect local conditions, regulations and laws.

12.2 Preconditions

- ◆ Installation and electrical connection have been correctly performed.
- ◆ Residual material from installation and foreign objects have been removed from the fan and ducts.
- ◆ Inlet and outlet are free.
- ◆ Safety devices have been fitted.
- ◆ Ground cable is connected.
- ◆ Cable glands are tight.
- ◆ Data on the name plate corresponds with the connection data.
- ◆ For EX fans, check whether the minimum air gap between the rotor and the housing matches the value stated in 6.6 *Minimum air gap*, page 6

12.3 Tests

- ◆ Before switching the fan on, check for externally visible damage and ensure that the protective equipment functions properly.
1. Switch the fan on.
 2. Do the tests requested in the commissioning report (18 *Commissioning Report*, page 20)
 - Speed controllable fans: "Measured data at commissioning" at maximum speed
 3. Switch the fan off.

13 Operation

13.1 Safety information



Danger

Risk of ignition of a potentially explosive gas/air atmosphere!

When commissioning the EX fan, the fundamental information from DGVU 113-001 (explosion protection rules (EX-RL)) and TRGS 727 (avoidance of risk of ignition as a result of electrostatic charges) must be known.

- ◆ Do not open or tip the fan if an explosive atmosphere exists.

Warning: Hazard from electrical voltage or moving components.

- ◆ The device may only be operated by adequately qualified persons, details see Table 1 *Qualifications*, page 3.

Important

Damage to the fan because of condensation water.

Ensure regular switch-on time of 2 hours per week

Warning: Risk by careless use of aggressive media.

Careless use of aggressive media can lead to very severe injuries.

- ◆ Pay attention to the safety data sheet of the chemical substances transported with the fan.
- ◆ Only use the fan in accordance with the operating instructions and the operating instructions for the motor.
- ◆ The EX fans have been admitted for S1 continuous operation.

14 Troubleshooting/maintenance/repair

Safety information

- ◆ Observe 3 *Important safety information*, page 2
- ◆ Pay attention to the safety data sheet of the chemical substances transported with the fan.



Danger

Loss of explosion protection

- The manufacturer must always be consulted before any maintenance or repair work is carried out! Repairs should preferably always be carried out by the manufacturer! Exceptions can be made for non-relevant components such as terminal boxes, screwed cable connections, etc. These can also be dealt with on-site by the operator's qualified staff (authorised personnel). Non-compliance will result in the ATEX certification being revoked!
- For ATEX-certified products, the repair or replacement of fan components is expressly only permitted after consultation with the manufacturer and only if the manufacturer's original parts are used!
- After repair, the fan/system must be subjected to an inspection in accordance with local conditions, regulations and laws (in Germany: §14 Abs 6 der BetrSichV Industrial Safety Regulation). This does not apply to repairs carried out by the manufacturer.

14.1 Troubleshooting

Table 6 Troubleshooting

| Problem | Possible causes | Remedy |
|----------------------------------------------------|-----------------------------------------------------------------------------|-------------------------------------------------------------------------------------------------|
| | Impeller imbalance | Rebalancing by a specialist company if possible, otherwise contact Systemair. |
| | Soiling on the impeller | Clean carefully, rebalance |
| | Material decomposition on the impeller due to aggressive material conveyed. | Contact Systemair |
| | | |
| Fan does not run smoothly | Impeller rotates in wrong direction. | Change direction of rotation (swap two phases in case of a 3-phase motor). Contact Systemair |
| | Deformation of impeller due to excessive temperature. | Ensure that the temperature does not exceed the certified value/Install new impeller. |
| | Vibrations, oscillations | Check the installation of the fan/check the duct system, see 10 <i>Installation</i> , page 11. |
| | Fan operation in resonant frequency range | Consider chapter 11.2 <i>Variable-speed fans</i> , page 13 |
| Air output of fan too low | Impeller rotates in wrong direction. | Change direction of rotation (swap two phases in case of a 3-phase motor). |
| | Wrong wiring configuration (e.g. Y instead of Delta). | Check and possibly correct the wiring configuration. |
| | Pressure losses too high. | Optimize the line routing. |
| | Flow regulators not or only partly open. | Check opening position on site. |
| | Intake or pressure ducts are blocked. | Remove the blockage. |
| Grinding sounds when starting or operating the fan | Check if the duct connections of the fan are strained. | Loosen the duct connections and realign it. |

Troubleshooting cont'd

| | | |
|--------------------------------------------------|-----------------------------------------------------------------------------------------------|-------------------------------------------------------------------------------------------------------|
| Thermal contacts/ resistors have triggered | Impeller rotates in wrong direction. | Change direction of rotation (swap two phases in case of a 3- phase motor). Contact Systemair |
| | Missing phase | In case of a 3 phase standard motor (not EC), check if all 3 phase are present. |
| | Motor overheated | Check the cooling impeller (if used), measure the motor winding (if possible) / contact Systemair. |
| | Motor blocked | Contact Systemair |
| Fan does not reach nominal speed | Defective motor winding | Contact Systemair |
| | Control units (if used) such as frequency converter or transformer are set incorrectly. | Correct the settings of the control units. |
| | Mechanical blockage | Remove the blockage. |
| Motor does not rotate | Frozen condensate blocking the impeller | Thaw and drain the condensate |
| | Faulty supply voltage | Check the supply voltage, re-establish the voltage supply. |
| | Faulty connection | Disconnect from the power supply, correct the connection, see circuit diagram. |
| Electronics/motor overheated | Temperature monitor has responded. | Allow the motor to cool down, find and resolve the cause of the fault. |
| | Insufficient cooling | Improve cooling. |
| | Overloaded motor | Check if the correct fan is used for your application. |
| | Ambient temperature too high | Check if the correct fan is used for your application. |



Note:

For all other damage/defects, please contact Systemair. Defective safety-relevant fans (for Ex and smoke extraction applications) must be replaced completely.

14.2 Maintenance

Warranty claims can only be made if maintenance work is carried out correctly and written evidence thereof is provided.

We recommend regular maintenance intervals to ensure continuous fan operation. These maintenance intervals are specified in the "Activities" table below. In addition, the operator must carry out follow-up activities such as cleaning, replacing defective components or other corrective measures. For traceability reasons, a maintenance plan must be created which documents the work carried out. This must be created by the operator. If the operating conditions are "extreme", the maintenance intervals must be reduced so that maintenance is carried out more frequently. Examples of extreme operating conditions:

- Durable ambient temperature > 35 °C or < 5 °C, or temperature fluctuations > 20 K
- Use in an explosion capable area

Table 7 Activities

| Activity | Normal operating conditions | | Extreme operating conditions | |
|-----------------------------------------------------------------------------------|-----------------------------|----------|------------------------------|------------------|
| | Every six months | Annually | Quarterly | Every six months |
| Check the fan and its components for visible damage, corrosion and contamination. | | X | | X |
| Check the impeller for damage and imbalance. | | X | | X |
| Clean the fan/ventilation system (see 15 <i>Cleaning</i> , page 19). | X | | X | |

Activities cont'd

| | | | |
|----------------------------------------------------------------------------------------------------------------------|---|---|---------------------------------|
| Check the screwed connections for damages/defects and check that they are firmly seated. | | X | See normal operating conditions |
| Check the fan intake is free from contamination. | | X | X |
| Check that the fan and its components are being used correctly. | X | | See normal operating conditions |
| Check the current consumption and compare this with the rated data. | | X | X |
| Check the vibration dampers (if used) are working correctly and check for visible damage and corrosion. | | X | See normal operating conditions |
| Check the electrical and mechanical protective equipment is working correctly. | | X | See normal operating conditions |
| Check the fan's rating plate is legible. | | X | X |
| Check the connection clamps and screwed cable connections for damage/defects, and check that they are firmly seated. | | X | See normal operating conditions |
| Check the flexible connectors for damage. | X | | See normal operating conditions |

14.3 Spare parts

- ◆ Use original spare parts from Systemair only.
- ◆ When ordering spare parts, please specify the serial number of the fan. This can be found on the name plate.

- 1 Motor
- 2 Flange plate
- 3 Motor disc
- 4 Impeller
- 5 Taper bush
- 6 Housing

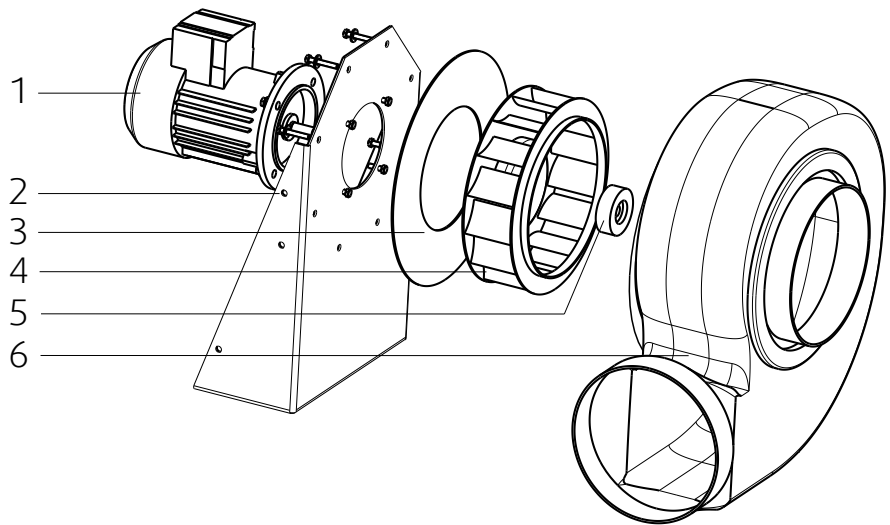

15 Cleaning

15.1 Safety information

- ◆ Cleaning may only be carried out by adequately qualified persons, details see Table 1 *Qualifications*, page 3.
- ◆ Observe the 5 rules of electrical safety, see 3.3 *5 rules of electrical safety*, page 3.
- ◆ The impeller must be at a standstill.
- ◆ Pay attention to the safety data sheet of the chemical substances transported with the fan.



Warning

Risk of ignition as a result of electrostatic charges.

Because of the MUB EX plastic parts in the housing, a damp cloth has to be used for cleaning to avoid the risk of ignition as a result of electrostatic charges.

15.2 Procedure

Important

Keeping the fan clean extends its service life.

- ◆ Drain condensation off
- ◆ Only use compressed air if the fan is used for conveying air in the presence of gases/vapours without hovering particles.
- ◆ If the fan is used in an environment with vapours of specific chemical substances, get information from the chemical safety data sheet with a view to the recommended cleaning products.
- ◆ Install a filter monitor.
- ◆ Do not use steel brushes or sharp-edged objects.
- ◆ Do not use a high-pressure cleaner (steam jet cleaner) under any circumstances.
- ◆ Do not bend the fan blades when cleaning.
- ◆ When cleaning the impeller, pay attention to balance weights that have been positioned
- ◆ Keep the airways of the fan clear and clean them if necessary with a brush.

16 Deinstallation/dismantling

- ◆ Pay attention to the safety data sheet of the chemical substances transported with the fan.
- Deinstall and dismantle the fan in reverse order of installation and electrical connection.

17 Disposal

- ◆ Ensure material is recycled. Observe national regulations.
- ◆ The device and the transport packaging are predominantly made from recyclable raw materials.
- ◆ Disassemble the fan into its components.
- ◆ Separate the parts according to:
 - reusable material
 - material groups to be disposed of (metal, plastics, electrical parts, etc.)

18 Commissioning Report

Warranty claims can only be made if commissioning work is carried out correctly and written evidence thereof is provided.

Fan

Description:

Article no.:

Manufacturing order no.:

Installer

Company:

Contact person:

Company address:

Tel. no.:

Email:

Operator (Place of installation)

Company:

Contact person:

Company address:

Tel. no.:

Email:

Type of connection

Directly to mains

Yes No

0-10 V signal (EC motor)

via contactor control

Transformer

Frequency converter

Sinus filter

Shielded cables

Motor protection

Motor protection switch or motor protection relay

Yes No

PTC resistor

Resistance value [Ω]:

Thermal contact

Electrical motor protection

Others:

Functional check

Impeller easily rotatable (by hand)

Yes No

Rotation direction acc. to directional arrow

Smooth running without unusual noise/
vibrations

Nominal data - Fan (name plate on fan housing)

Voltage [V]:

Current [A]:

Frequency [Hz]:

Power [kW]:

Fan impeller speed [rpm]:

Measured data at commissioning

Voltage [V]:

Temp. of transported air [$^{\circ}\text{C}$]:

| | |
|-------------------------------------------------------|-------------------------------------------------------------------------|
| Current L1 [A]*: | Fan impeller speed [rpm]: |
| Current L2 [A]: | <i>"Air volume", "Differential pressure" not necessary for Jet fans</i> |
| Current L3 [A]: | Air volume [m ³ /s]: |
| *For single-phase fans, fill in line "Current L1 [A]" | Differential pressure [Pa]*: |
| | *Δ- Pressure between suction-side and discharge of the fan |

If an air flow measurement is not possible, this value can be calculated using the following formula:

| | | | | |
|--------------------------------------|---|------------------------------------------------------------------------|---|---------------------------------|
| | X | | = | |
| Duct cross-section [m ²] | | Flow speed [m/s] <small>Grille measurement acc. to VDI 2044</small> | | Air volume [m ³ /s]: |

| | | |
|--------------------------------------|--------------------------|--------------------------|
| | Yes | No |
| Commissioning of the fan successful? | <input type="checkbox"/> | <input type="checkbox"/> |

Date, installer's signature

Date, operator's signature



Systemair GmbH
Seehöfer Str. 45
97944 Boxberg
Germany

Tel.: +49 (0)7930/9272-0
Fax: +49 (0)7930/9273-92

info@systemair.de
www.systemair.de