

Bend

BTR 90°



Description

Pressed and seam welded bend.

Dimensions

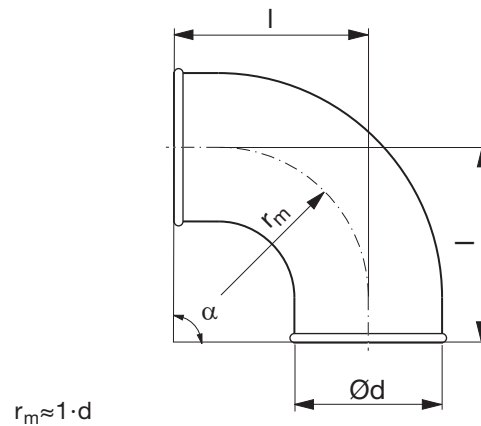

Ød nom	t mm	r _m mm	l mm	m kg
80	0,5	100	135	0,31
100	0,5	100	130	0,30
125	0,5	125	155	0,50
140	0,5	140	170	0,70
150	0,7	150	180	0,80
160	0,6	160	190	0,65
180	0,7	180	205	1,00
200 **	0,7	200	252	1,20
224 **	0,7	225	277	1,37
250 **	0,7	250	302	1,71

** 2 swaged-on ends

Ordering example

	BTR	125	90
Product			
Dimension Ød			
Angle α			